



WARMING DISPLAYS

CONCEPT

COUNTERTOP WARMING DISPLAYS

Compact heated display units offer panoramic view of merchandise

- Stainless steel construction
- Concealed fluorescent light fixture and lighted graphics panel on WDL models
- Thermostatically controlled up to 225° F
- Dual service from front and back with lift up doors
- Equipped with water pan for humidity
- Removable bottom crumb tray
- Equipped with lighted switches
- WDL models available in stainless steel or matte gold finish

TUDOR



- * Two shelves
- * Exterior dimensions: 24"Wx14"Dx16"H
- * Shelf size: (2) 21 1/2"Wx13"D
- * Inside clearance: 5 1/4"
- * Optional single service door locking device

WONDER

WDL-100

120 V



- * One shelf
- * Exterior dimensions: 24"Wx14"Dx12"H
- * Shelf size: 21 1/2"Wx12 3/4"D
- * Inside clearance: 6 1/2"

TOP GON

WD-100

120 V



- * See thru plexiglass top
- * Same as WDL-100 without light - 9 1/2"H
- * Stainless steel finish

GONAGAIN

WD-200

120 V



- * See thru plexiglass top
- * Same as WDL-200 without light - 14"H
- * Stainless steel finish



765 WESTMINSTER STREET PROVIDENCE, RI 02903
 TEL: (401)273-3300 FAX: (401)273-3328 E-mail:sales@equipex.com
 www.equipex.com



COUNTERTOP WARMING DISPLAYS

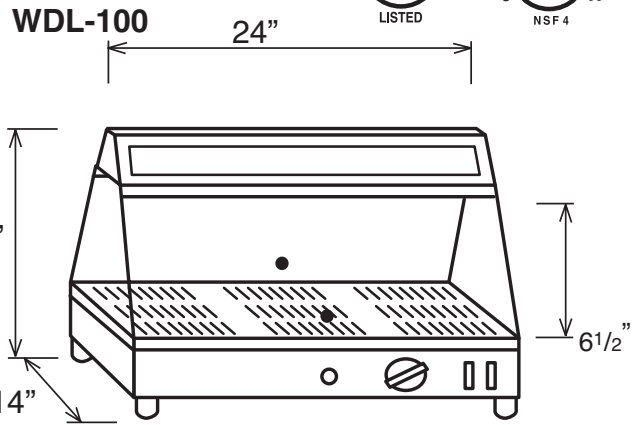
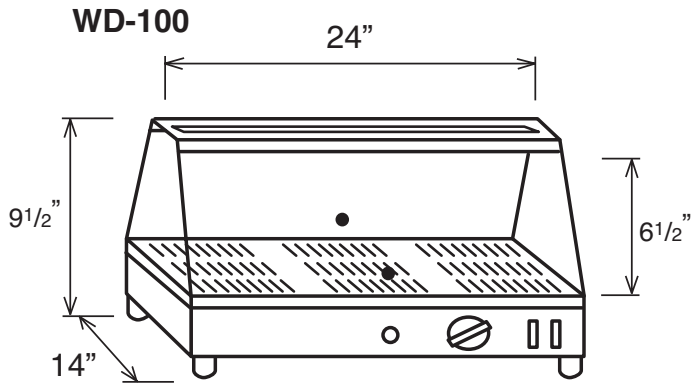

WDL-200
 - Top and bottom shelves hold half size sheet pan
 - Bottom shelf holds 12"x20" pan
 24"

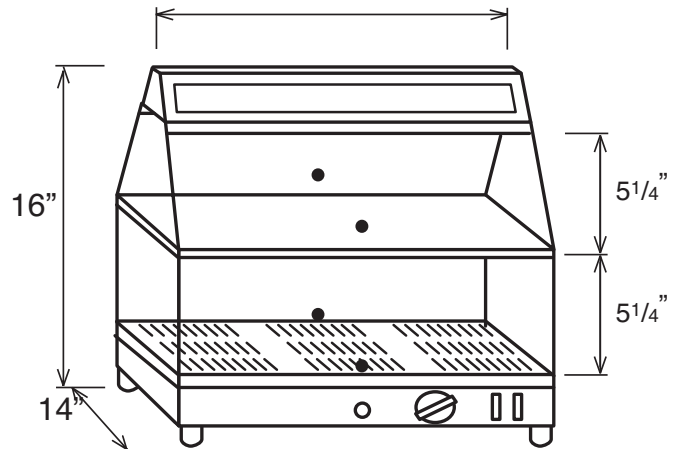
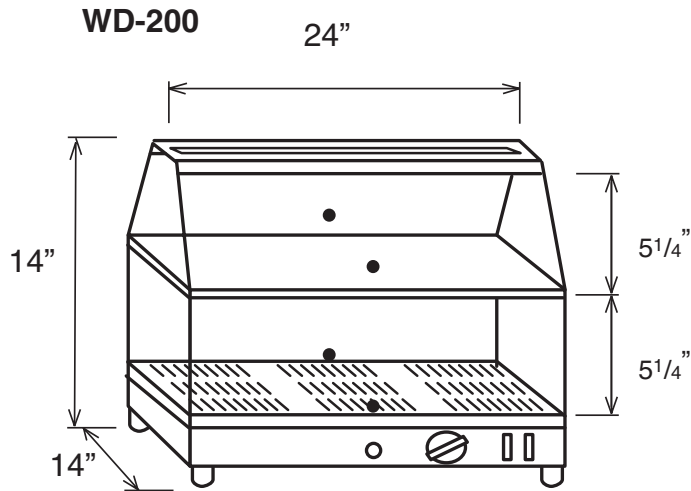

Options: - stainless steel exterior
 - matte gold exterior

SPECIFICATIONS

MODEL	ELECTRICAL	EXTERIOR DIMENSIONS	SHELF DIMENSIONS	SHIPPING WEIGHT	NEMA PLUG
WD-100	120V, 750W, 7 Amps	24"Wx14"Dx9 1/2"H	21 1/2"Wx12 3/4"D	20 lbs	5-15 P
WD-200	120V, 750W, 7 Amps	24"Wx14"Dx14"H	(2)21 1/2"Wx13"D	30 lbs	5-15 P
WDL-100	120V, 750W, 7 Amps	24"Wx14"Dx12"H	21 1/2"Wx12 3/4"D	26 lbs	5-15 P
WDL-200	120V, 750W, 7 Amps	24"Wx14"Dx16"H	(2) 21 1/2"Wx13"D	34 lbs	5-15 P

WARRANTY: Limited one year parts and labor



765 WESTMINSTER STREET PROVIDENCE, RI 02903
 TEL: (401)273-3300 FAX: (401)273-3328 E-mail:sales@equipex.com
 www.equipex.com